

This product should only be fitted by a qualified plumber to NVQ (National Vocational Qualification) or SNVQ (Scottish National Vocational Qualification) Level 3. Should the installation be completed by a non-qualified person then the guarantee may be considered invalid.

For a claim made under our warranty written certification of your installers credentials can be required. For further information or to find a qualified installer in your area please visit the Institute of Plumbers website - [www.iphe.org.uk](http://www.iphe.org.uk)

## THE QUALIFICATIONS

At present, to be a plumber you need to follow the National Vocational Qualification (NVQ) route (Scottish National Vocational Qualification - SNVQ - in Scotland). These qualifications are made up of theory and practical work in the classroom/purpose built training facility and work based experience with a working plumber. Colleges should help students find a work placement, although many students organise it themselves.

The S/NVQ qualification works in levels. All recently qualified plumbers should hold S/NVQ Level 2 as basic with Level 3 as the preferred level. Level 2 will give you the foundation you need for a career in plumbing and teach you domestic plumbing to a satisfactory level. Level 3 is more comprehensive and deals with domestic, commercial and industrial plumbing along with aspects such as gas - if you want to one day set up your own business, this is the level to reach. The Institute of Plumbing and Heating Engineering, and the industry as a whole recommends that all plumbers reach a minimum of Level 3.

Reaching Level 3 has other advantages. The Institute runs a Master Plumber Certificate, which only those attaining Level 3 or equivalent can reach as long as they have the relevant experience as well. Those with S/NVQ Level 3 can (once in membership with the Institute for five years as a Member MIPHE) gain Engineering Technician EngTech status with the Engineering Council (UK).

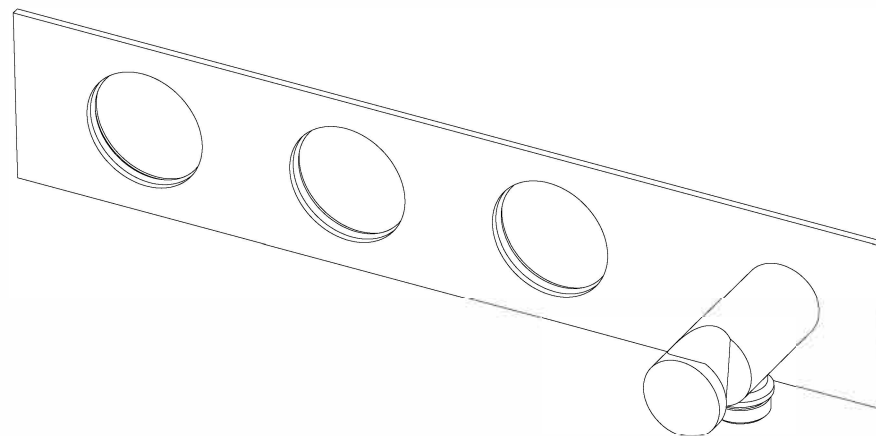

For any further information please contact  
Crosswater on: **0845 873 8840**

Or visit our web-site at [www.crosswater.co.uk](http://www.crosswater.co.uk)

The manufacturer reserves the right to make technical  
modifications without prior notice.

## INSTALLATION INSTRUCTIONS

**INTRODUCTION**

**Please read these instructions carefully and keep in a safe place for future reference.**

**General Installation Requirements.**

The installation must comply with regulations of the Local Water Authority as contained in their bylaws. All of the taps in this range are single flow (the hot and cold water mix in the body) and should therefore be supplied with hot and cold water at balanced pressures, both from the tank or both from the mains (via a combination boiler for example). If the taps are not supplied at balanced pressures then the mixer will not function correctly. It will also be necessary to fit non-return valves on both hot and cold feeds. It is very important that all pipework is flushed thoroughly after installation to avoid damaging the ceramic discs.

**Minimum/Maximum working pressure**

These taps are suitable for high and mid pressure installations. They are fitted with a quarter turn ceramic disc cartridge which provides a good flow rate with very smooth movement. To ensure that the bath filler works adequately under low pressure, the cold water storage tank should be at least 2 metres above the highest installed position. The maximum water pressure is 4 bar (note: mains cold water is normally supplied at between 2 and 3bar). For installations where the mains pressure exceeds 4 bar a pressure reducing valve should be fitted.

**Approvals**

All products are manufactured using materials tested and approved under the Water Bylaws Scheme and comply with requirements of British Standard 5412:1996 where applicable.

**Preparation and byelaw requirements**

These taps are single flow so the hot and cold water mix in the body. Water byelaws require that where the hot water is supplied from a tank and cold from the mains, non return valves are fitted on both hot and cold pipes as close as possible to the tap. These are not supplied. Where combination boilers are fitted it is only necessary to shut off the incoming mains and turn the boiler off and non return valves are not required.

**WARNING**

**Before installing the new mixer it is essential that you thoroughly flush through the supply pipes in order to remove any remaining swarf, solder or other impurities. Failure to carry out this simple procedure could cause problems or damage to the working of the mixer.**

These hints have been prepared for your guidance, you must exercise due care at all times. We do not accept responsibility for any problems that may occur through incorrect installation.

**DIMENSIONS**

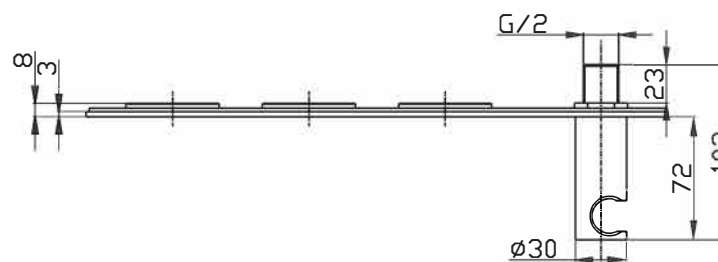
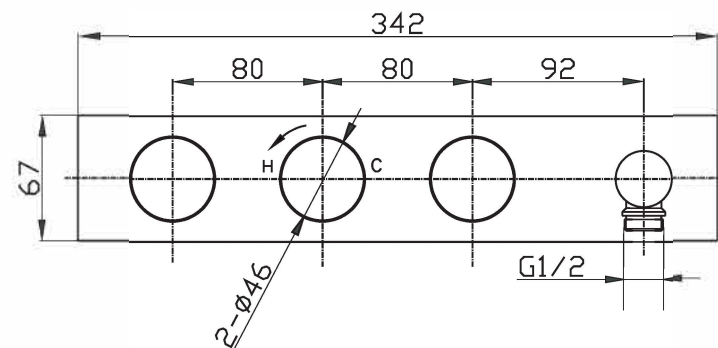

**NOTE: ALL DIMENSIONS IN MILLIMETRES**

INSTALLATION

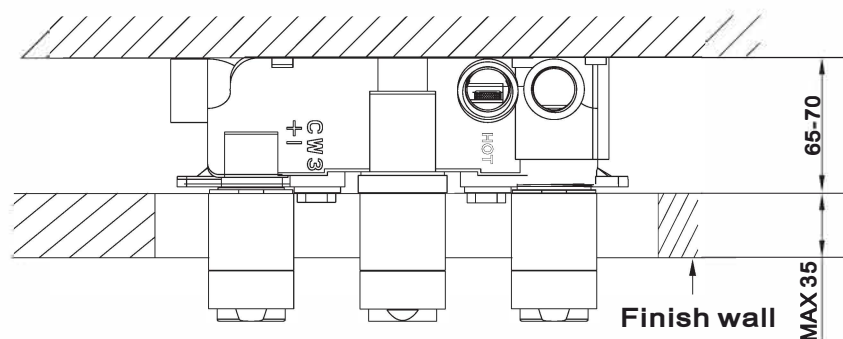
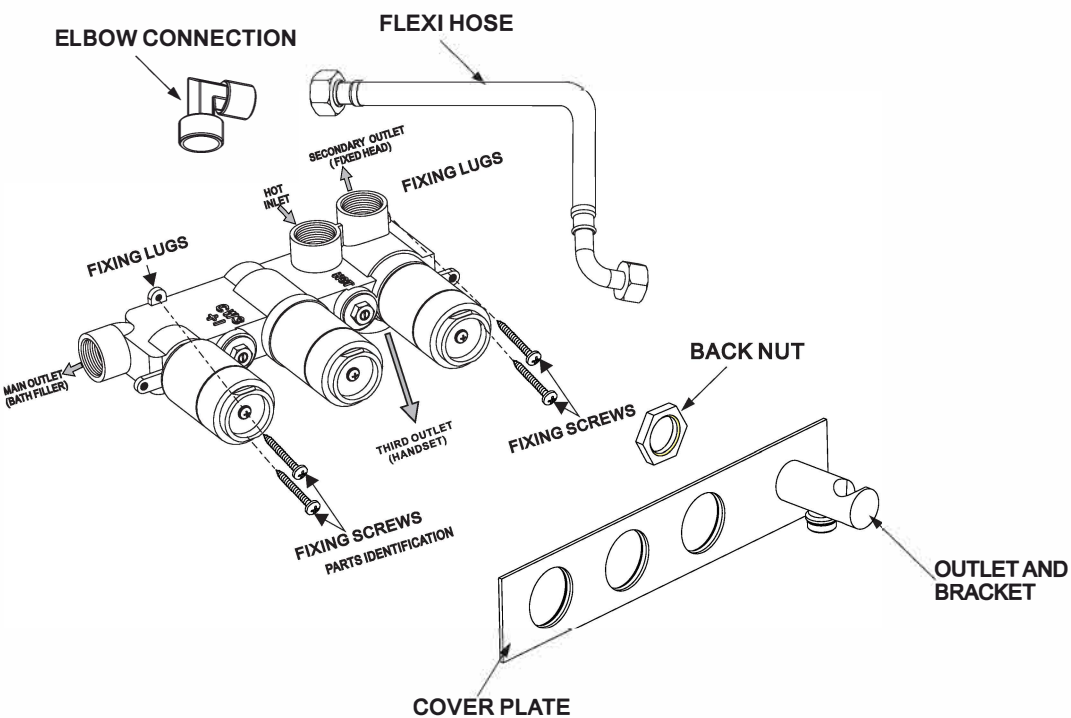

INSTALLATION

INSTALLATION

- ⚠ Remember to turn off the mains water supply before connecting to any existing pipe work.**  
**Warning! Please check for any hidden pipes and cables before drilling holes in the wall.**

Position the valve onto the wall and mark the position of the fixing lugs (x4). Make sure the valve is set back from the front face of the wall by the appropriate depth to allow for plasterboard, filling and tiling etc. (min. 78mm to max. 105mm see dimension page).

Mount casting to the wall using suitable fixings.

Always leave access to the four front cartridges for servicing.

Once the valve has been secured to the wall, the black Plastic Dust Cover can be temporarily attached to the valve with the screws supplied. This will protect the valve while the rest of the work is completed (see fig 1).

**First make connection main outlet (bath or fixed head) from the outlet on the underside of the valve.**

Connect the 90° elbow provided to the secondary outlet of the valve pointing it to the right. Then fix the straight end of the flexi hose onto this elbow.

The other end of the flexi hose is then connected to the male treaded stud on the wall side of the cover plate.

- ⚠ Do not use tapered threaded adaptors or excessive thickness of sealing tape as this may damage the valve body and result in a concealed leak within the wall cavity.**

Remove the Plastic Dust Cover.

- ⚠ Turn on supplies and test all connections for water tightness.**

Remove Hot and Cold check valves, and flush out the installation, clean the filters and refit.

Apply a narrow bead of clear silicone sealant around the back edge of the cover plate and carefully press into position.

Fit the control knobs by lining up the flat surface of the valve cover with the grub screw on the handle, tighten the screw with the supplied hexagonal key (see fig 2).

