

# CENTRAL

Exposed Thermostatic Shower Column



## PRODUCT CODES:

RM531Wx



### IMPORTANT INFORMATION BEFORE YOU START

**Please read these instructions carefully and keep in a safe place for future reference.**

#### General Installation Requirements

The installation must comply with regulations of the Local Water Authority as contained in their bylaws. All of the taps in this range are single flow (the hot and cold water mix in the body) and should therefore be supplied with hot and cold water at balanced pressures, both from the tank or both from the mains (via a combination boiler for example). If the taps are not supplied at balanced pressures then the mixer will not function correctly. It is very important that all pipe work is flushed thoroughly after installation to avoid damaging the ceramic discs.

#### Minimum/Maximum working pressure

These taps are suitable for high and low pressure installations they are fitted with a ceramic disc cartridge which provides a good flow rate with very smooth movement. To ensure that the mixer works adequately under low pressure, the cold water storage tank should be at least 2 metres above the highest

installed position. The maximum water pressure is 10 bar (note: mains cold water is normally supplied at between 2 and 3 bar). For installations where the mains pressure exceeds 5 bar a pressure reducing valve should be fitted.

#### Approvals

All products are manufactured using materials tested and approved under the Water Bylaws Scheme and comply with requirements of British Standard 5412:1996 where applicable

#### Warning

**Before installing the new mixer it is essential that you thoroughly flush through the supply pipes in order to remove any remaining swarf, solder or other impurities. Failure to carry out this simple procedure could cause problems or damage to the workings of the mixer.**

These hints have been prepared for your guidance, you must exercise due care at all times. We do not accept responsibility for any problems that may occur through incorrect installation.

**DIMENSIONS**

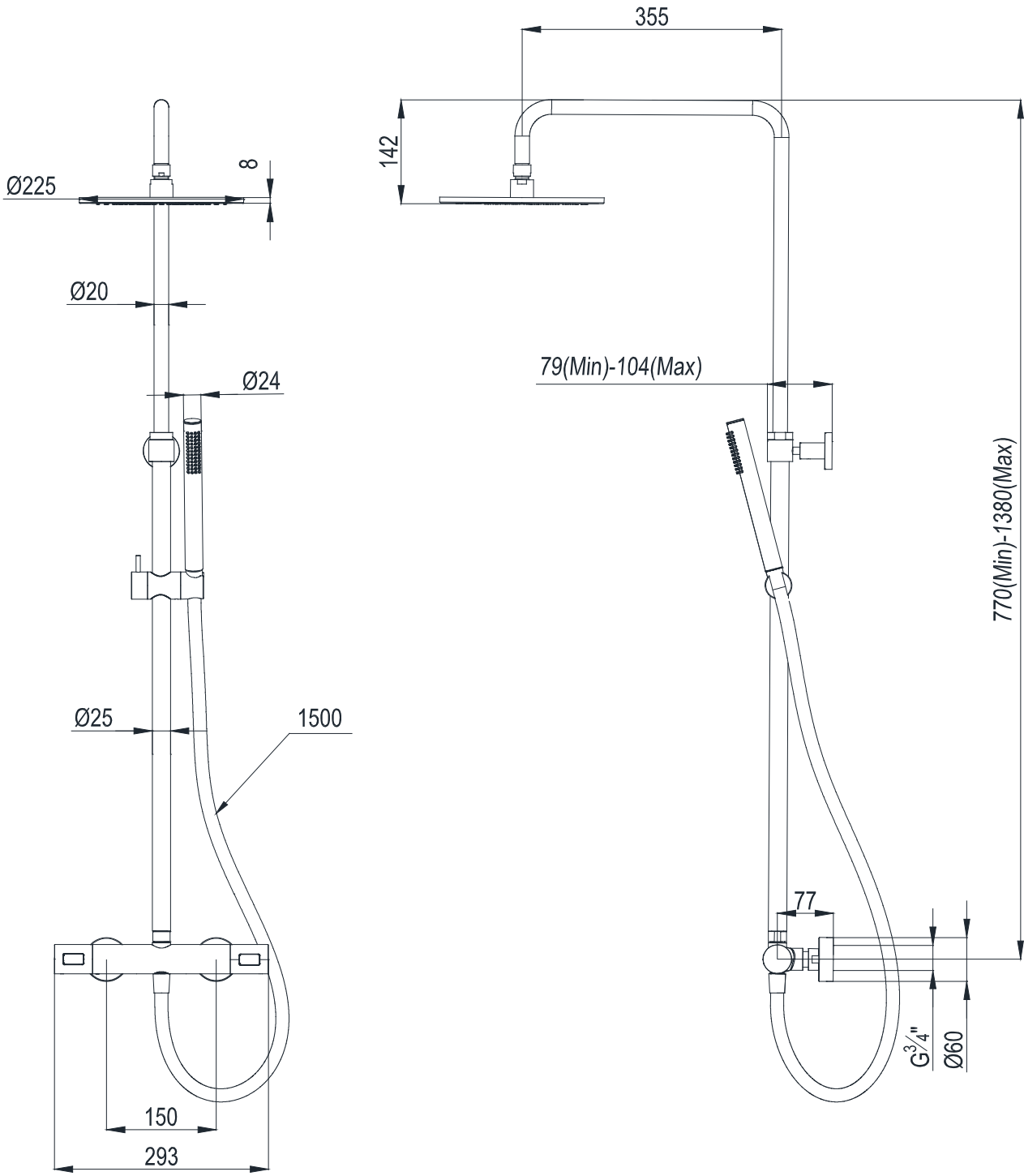

NOTE: ALL DIMENSIONS IN MILLIMETRES

INSTALLATION

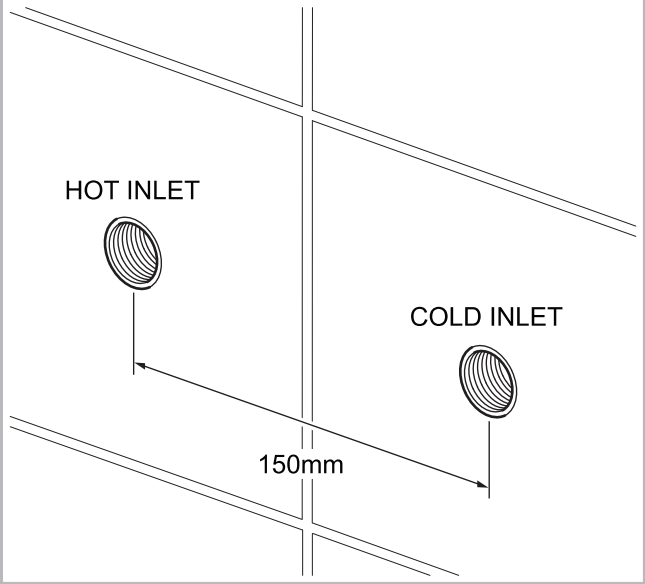

FIG. 1 PREPARING INLET CONNECTIONS

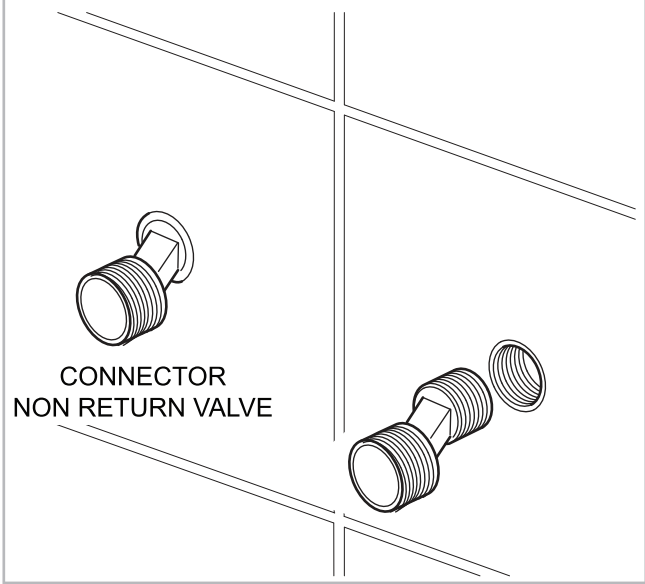
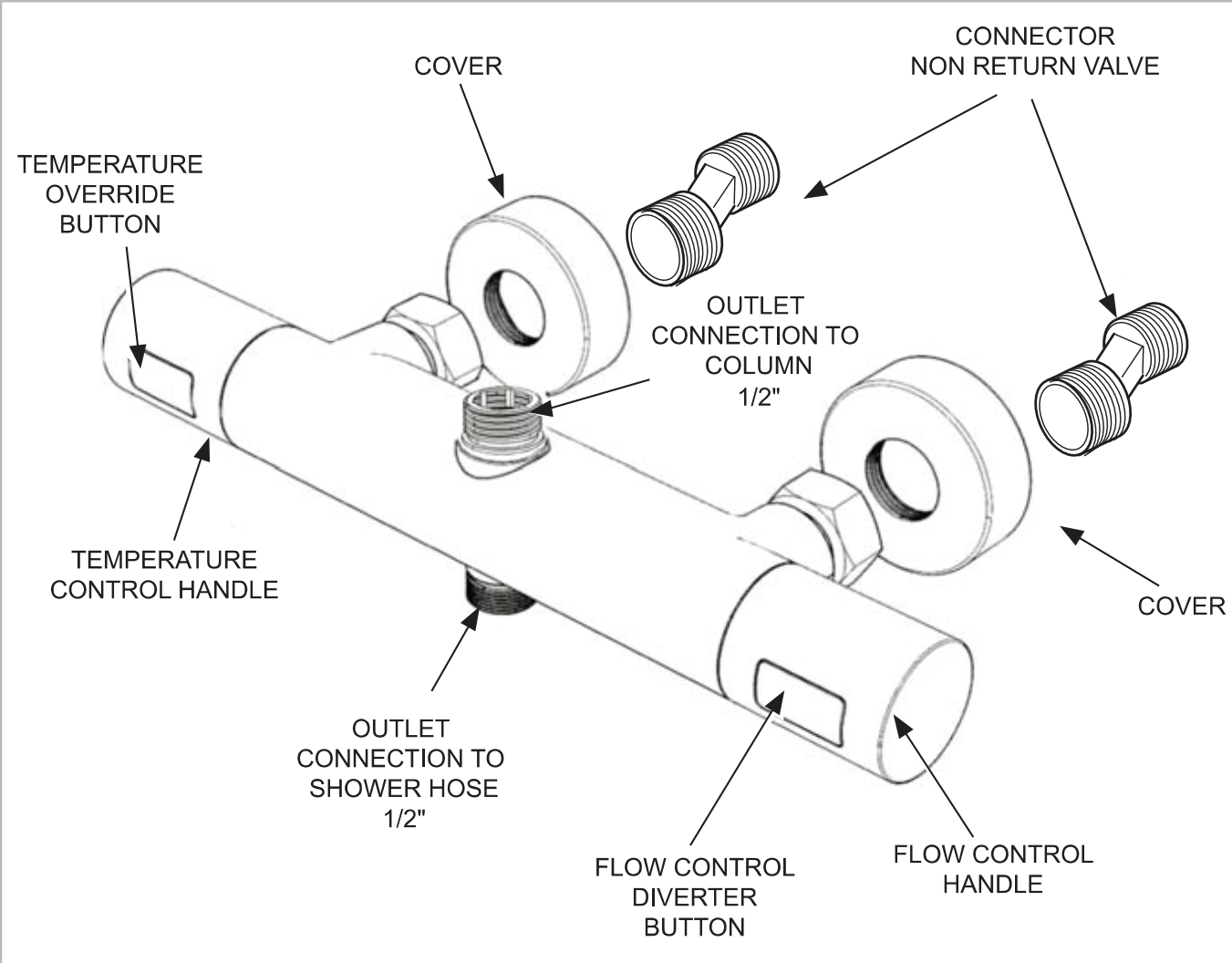

FIG. 2 FITTING THE 'S' CONNECTORS



## INSTALLATION

First shut off your water heating system then, with your mains stop cock closed, open the lowest hot and cold taps in the house and allow to run until the cold storage tank and pipes are empty (the hot water storage cylinder always remains full). Where combination boilers are fitted it is only necessary to turn off the boiler and shut off the incoming mains. Fitting isolating valves to the inlet feeds is recommended for ease of maintenance.

## INSTALLATION

**⚠ Remember to turn off the mains water supply before connecting to any existing pipe work.**

**⚠ Warning! Please check for any hidden pipes and cables before drilling holes in the wall.**

### Preparing the pipe work.

As the valve has no means of fixing to the wall it needs to be supported on rigid pipe work. Prepare the supply pipes (hot on the left and cold on the right) at the required height with a width of 150mm centres, making the ends of the adaptors level with the face of the wall, see fig 1.

Screw each connector/non return valve into the adaptors in the wall see fig 2.

### Valve.

Push a cover into the inlets in the valve body. Mount the body onto the "S" connectors and tighten each of the hexagonal mounting screws on the underside of each inlet.

## INSTALLATION

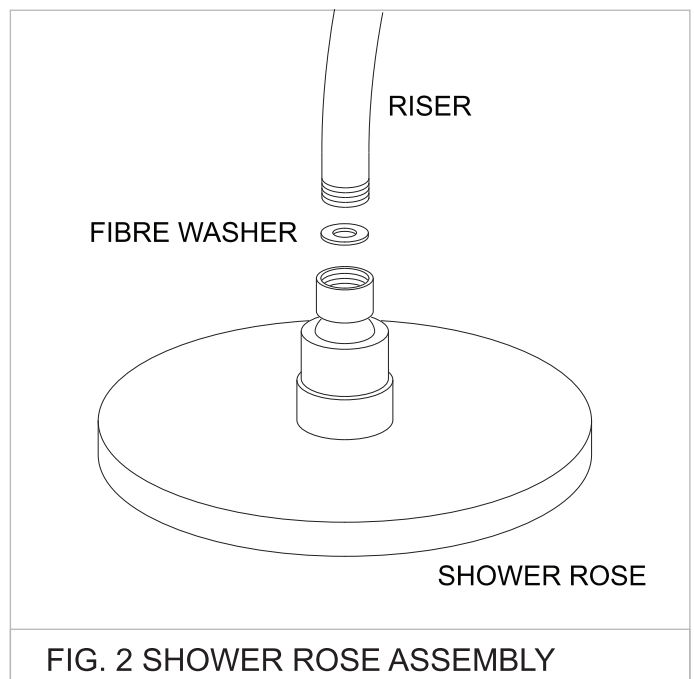
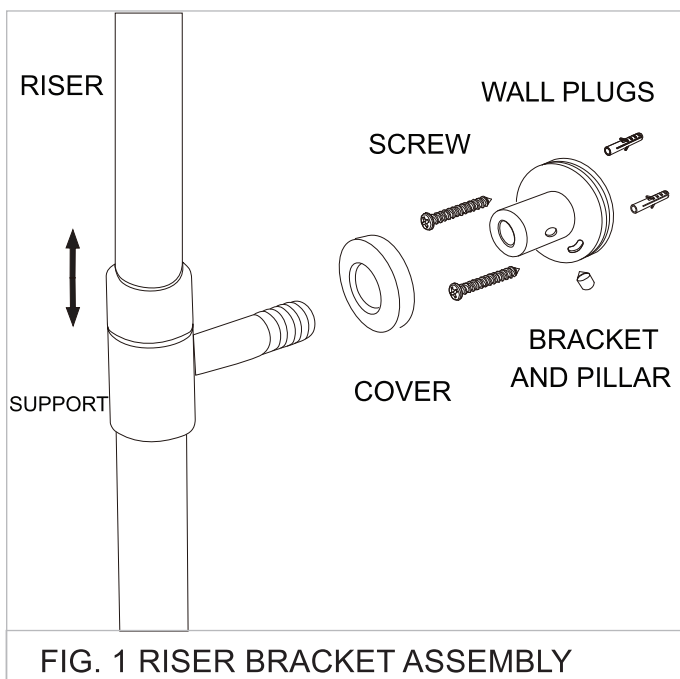

## INSTALLATION

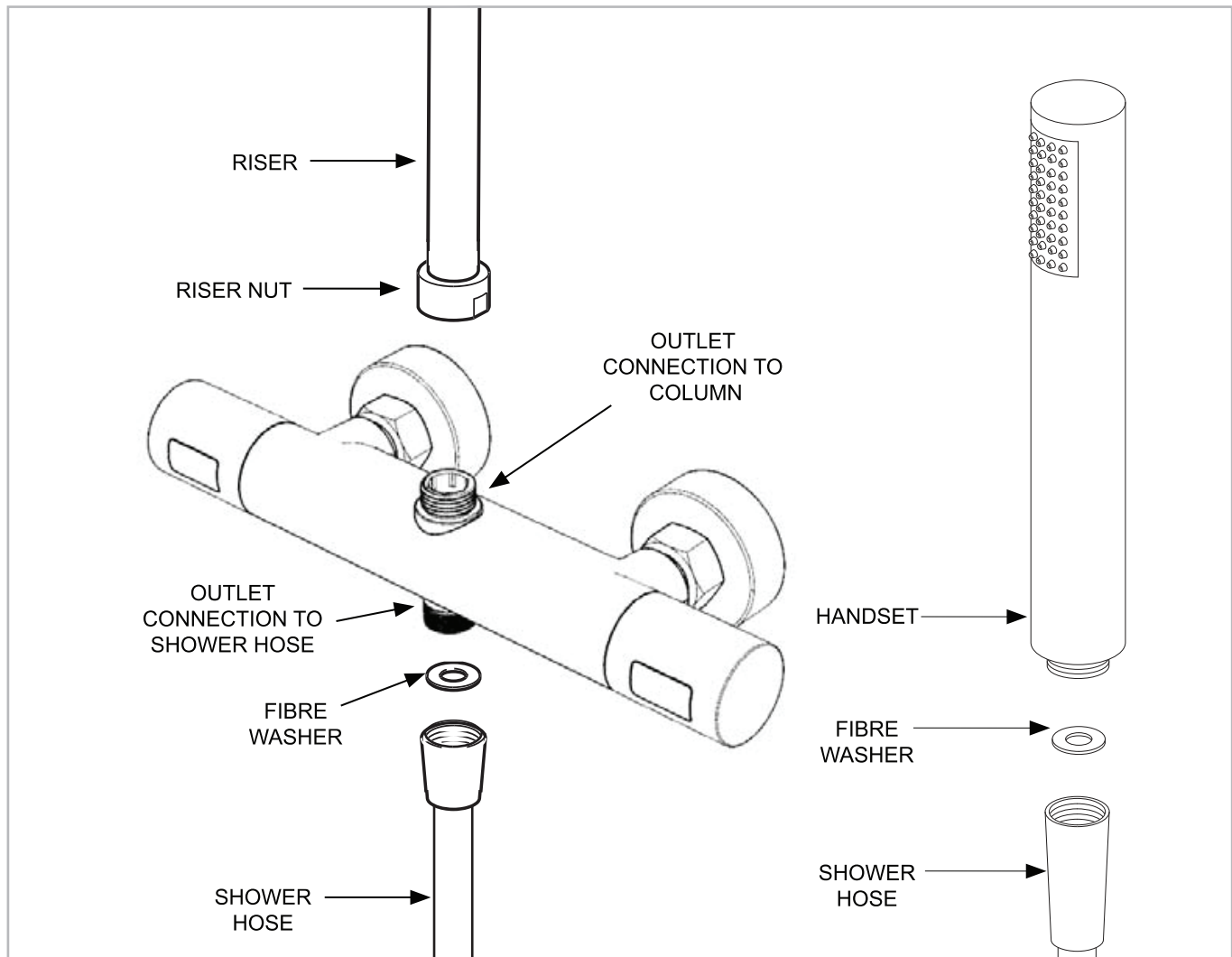

## INSTALLATION

**⚠ Warning! Please check for any hidden pipes and cables before drilling holes in the wall.**

### Fixing the riser

Mark a vertical center line from the valve up the wall, slide the riser support onto the riser from the bottom followed by handset holder, temporarily position the riser into the valve. Mark the position of the riser support on the wall making sure that the riser support is below the curve of the riser.

Place the bracket on the centre line and mark the position of the two fixing holes. Drill the 2 x 6mm holes to a depth of 35mm and insert the wall plugs.

Secure the bracket to the wall using the supplied screws, and slide on the cover (see fig 1).

Secure the shower rose to the riser using the fibre washer (see fig 2).

Remove the riser nut and 'O' ring from the valve and slide onto the riser. Push the riser down into the connection outlet on the valve, slide down the 'O' ring and tighten the riser nut.

Slide the riser support to meet the bracket and screw together. There are 2 flats on the bracket pillar to aid tightening.

Insert a fibre washer into the long cone end of the hose and screw to the handset. Insert the second fibre washer into the short cone end of the hose and attach it to the mixer outlet.

## MAINTENANCE

Before carrying out any maintenance please remember to turn OFF all mains water and turn ON the isolating valves.

### THERMOSTATIC CARTRIDGES

The concealed thermostatic valve should give trouble free service, but in the event of failure, servicing is straight forward. **To remove the thermostatic cartridge** Using the hexagonal key undo and remove the screw on the underside of the valve (keep in a safe place). Pull the thermostatic cartridge away from the valve body complete with the handle. Wash the cartridge and clean with running water and make sure that any trapped debris has been removed. Dry and lightly grease the seals using silicone grease only and replace the cartridge and handle making sure the hole in the cartridge is lined up with the hole in the body. Refit the screw and tighten using the hexagonal key.

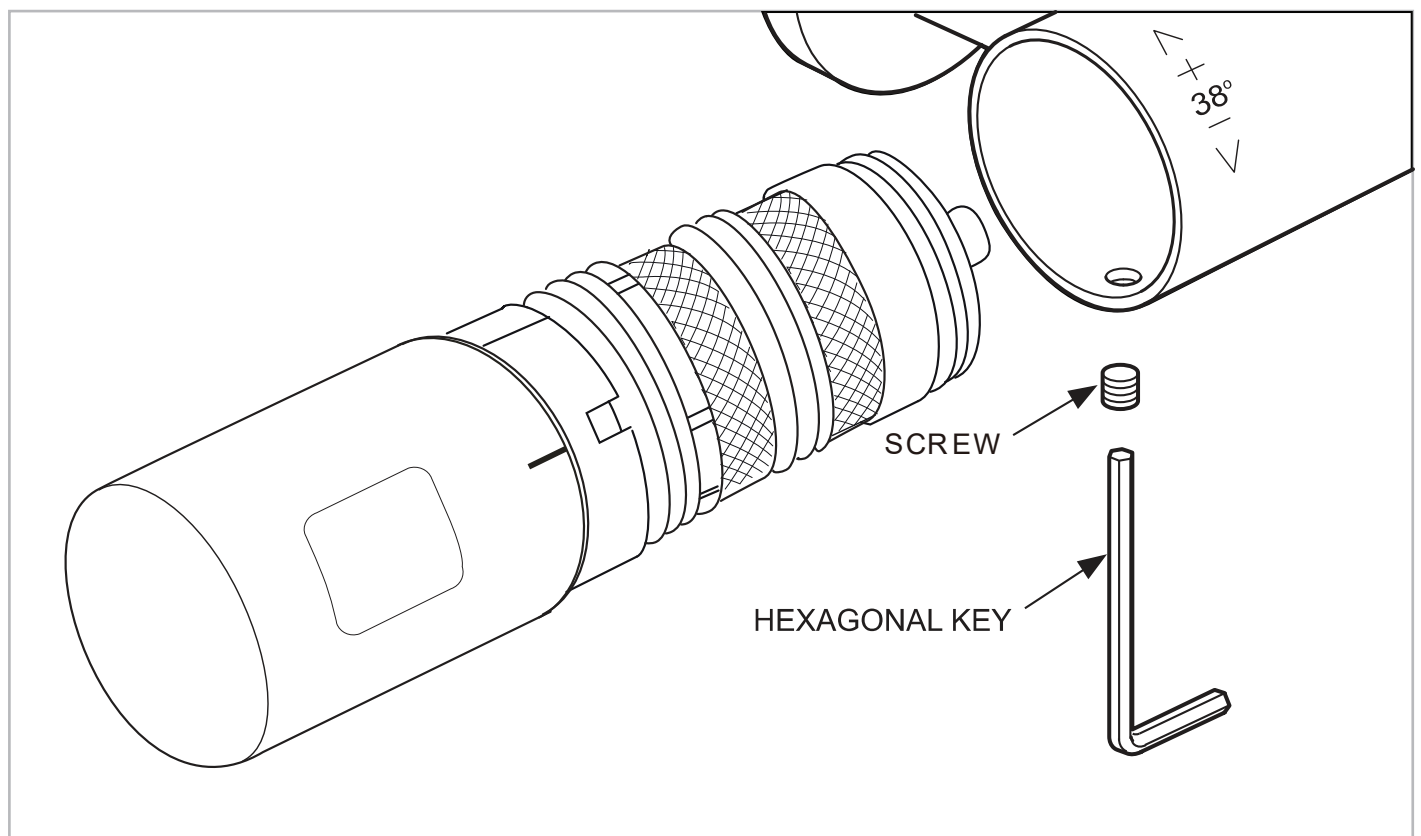

### FLOW CONTROL CARTRIDGE

The Flow Control Cartridge uses ceramic discs which normally last indefinitely unless debris manages to get between them. Wash the cartridge with clean running water, dry and lightly grease the seal.

### FILTERS

Turn off water supply to the valve and remove from the wall. Using a 29 wrench key undo the retaining nut within each of the inlets. Wash the filters with clean running water and replace.

## OPERATION

Turn the Flow control handle away from you to increase the flow of water to the shower rose. To divert the water to the handset press the button and turn the control handle towards you. Return the control handle to the upright position with the button on top to turn off the flow of water.

Turn the Temperature control handle to increase or decrease the temperature. Push down on the Override button and turn the handle towards you to override the set temperature. To change the set temperature see section on page 7 Temperature setting.

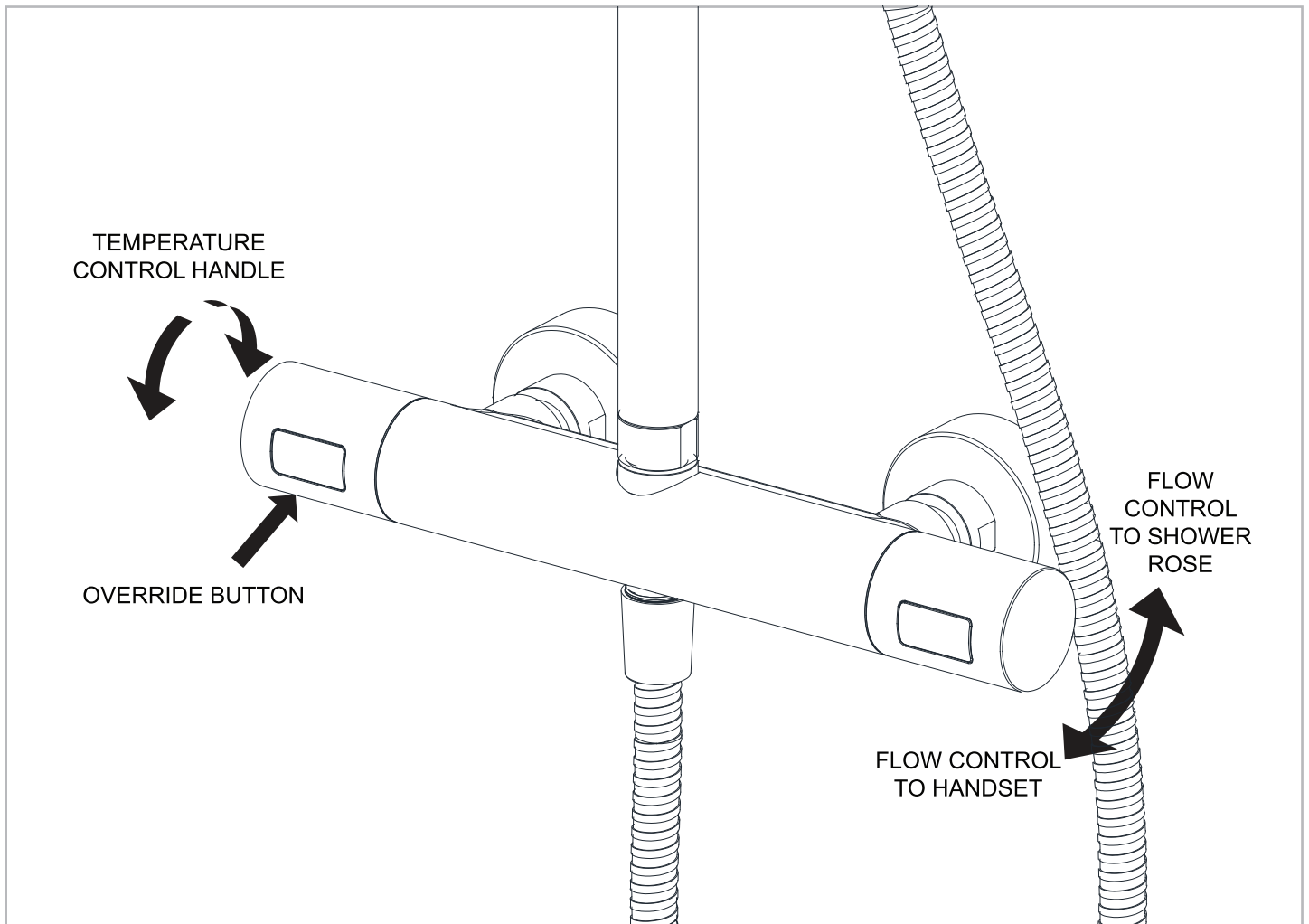

## CLEANING

### CARE OF YOUR SHOWER VALVE & RISER

we recommend cleaning the valve with a soft damp cloth. We strongly advise against the use of ALL cleaning products

### SHOWER ROSE & HANDSET

Your shower rose and handset has rub clean nozzles for easy cleaning. Rub your fingers across the rubber nozzles to remove any scale or debris. If you live in a hard water area you might have to repeat this procedure regularly.

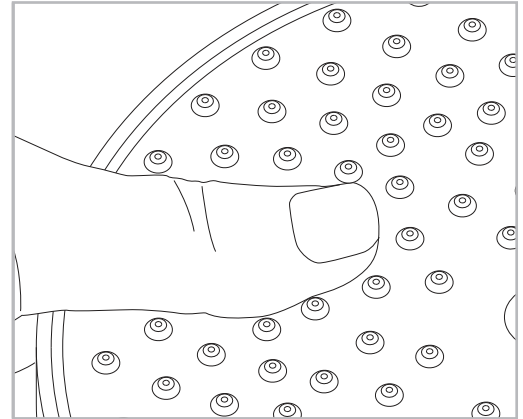

## TROUBLE SHOOTING

SYMPTOM	SOLUTION
After installation the shower runs HOT or COLD and will not mix.	Hot and cold supplies are plumbed the wrong way round.
Shower will not run hot enough when first installed.	Maximum temperature needs adjusting, see 'temperature setting'.
Cold water tracking through the valve into the hot water system.	Check and clean the filters.
Very low flow or no flow (gravity).	Check hot and cold feeds (the valve will shut down if either the hot or cold supply fails).