

## Glide II Worktops

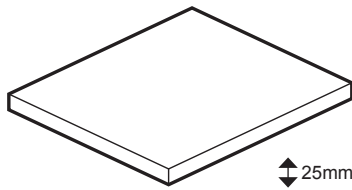

25mm

GL5000TMC	500mm	11kg
GL6100TMC	600mm	16kg
GL7000TMC	700mm	16.2kg
GL8100TMC	800mm	21kg
GL9100TMC	900mm	25kg
GL1000TMC	1000mm	23kg
GL1100TMC	1100mm	25kg
GL1210TMC	1200mm	28kg
GL1410TMC	1400mm	32kg

## Infinity Worktops

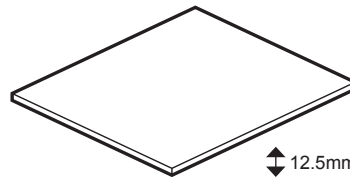

12.5mm

IF5100TPW	500mm	6kg
IF5100TMC+	500mm	6kg
IF7100TMC+	700mm	8kg
IF7100TPW	700mm	8kg
IF9100TMC+	900mm	10kg
IF9100TPW	900mm	10kg
IF1010TMC+	1000mm	11kg
IF1010TPW	1000mm	11kg
IF1210TMC+	1200mm	14kg
IF1210TPW	1200mm	14kg
IF14100TPW	1400mm	16kg
IF1410TMC+	1400mm	16kg

## Svelte Worktops

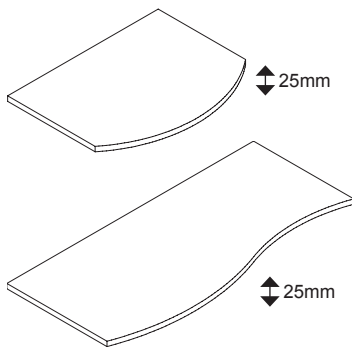

25mm

25mm

SE6000TMC	600mm	14kg
SE8000TMC	800mm	19kg
SE1000STMC	1000mm	24kg

## Canvass Worktops

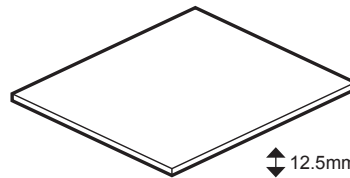

12.5mm

FWT495CM	495mm	7kg
FWT610CM	600mm	9kg
IF7100TMC+	700mm	8kg
IF9100TMC+	900mm	10kg



## IMPORTANT - Advice and safety - Please read before installation

**Please read these instructions carefully before starting installation and keep in a safe place for future reference. ENSURE the room is well heated and ventilated.**

Check the contents of the pack carefully before installation. Crosswater will not be held responsible for any de-fit / re-fit costs where faulty product has been fitted.

If any fault is found with materials or workmanship, it must be reported immediately to the manufacturer. Remedial action will be taken, based on information received, on condition that:

1. Full details are supplied to the manufacturer;
2. The product has not been modified or tampered with;
3. The manufacturer is informed of any damage/shortages prior to installation.
4. The product has not been installed, or attempts have been made to install.

We do not accept responsibility for any problems that may occur through incorrect installation.

### Advice & Safety

This product should only be fitted by a qualified plumber to NVQ (National Vocational Qualification) or SNVQ (Scottish National Vocational Qualification) Level. Should the installation be completed by a non-qualified person then the guarantee may be considered invalid.

For a claim made under our warranty written certification of your installers credentials can be required. For further information or to find a qualified installer in your area please visit the Institute of Plumbers website - [www.iphe.org.uk](http://www.iphe.org.uk)

This document has been prepared for your guidance, you must exercise due care at all times.

### Important pre-installation notes

These worktops were developed to make solid surface an easy fit option without the need for specialist templates or tooling. By following these instructions we know that competent installers can achieve excellent results.

#### Preparation

The worktops must be conditioned for at least 24 hours at room temperature prior to fitting. Worktops MUST be stored horizontal and flat in a dry, well-ventilated area. Worktops must not be stored vertically and on one edge.

**WHEN MAKING A CUT OUT WE WOULD RECOMMEND THAT THE WORKTOP IS PLACED ON A SOLID SUBSTRATE WHILST MACHINING.**

The surfaces are supplied with a final matt finish and do not require any further surface finishing apart. The worked edge on drilled holes may need sanding to remove any rougher sections.

**Warning!** Please check for any hidden pipes or electrical cables before drilling holes in the floor or walls.

When using power tools always follow the manufacturer's user instructions.

This installation guide details fitting to a solid wall. If your bathroom has studded/plasterboard walls, please use appropriate plasterboard fixings.

Please ensure the wall can take weight of units detailed above. Before installing a wooden bathroom unit into a new property, extension or recently plastered room we strongly advise the building/room is completely dry, well ventilated and adequately heated.

The manufacturer reserves the right to make technical modifications without prior notice.

# INSTALLATION INSTRUCTIONS

crosswater<sup>®</sup>

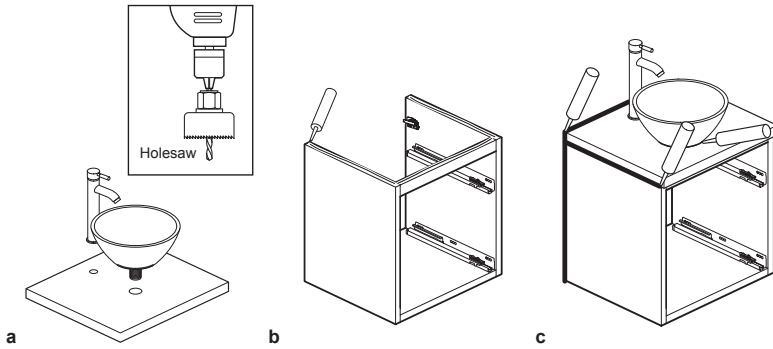

a. Prepare worktop for taps and basin waste. Cut holes where required using a suitable sized 'holesaw' at a slow speed.

b. Carefully apply silicone to the top edges of the unit.

c. Carefully position worktop down onto the unit, ensure it is centrally positioned and flush at the back.

Connect the tap and waste. Apply silicone to the join between the worktop and wall, between the worktop and unit, down the sides of the unit and around the base of the basin.

Leave silicone to dry for 24 hours.

## Useful Advice

When tiling down to the work surface leave a minimum of 3mm gap between the bottom row of tiles and the work surface.

This gap should be sealed with a silicone sealant.

## Care and Maintenance

### Surface finish

Over a short period of time in use in the home, your worktops will develop a smoother finish and more lustrous appearance. In the first days after installation the dry finish of the surface may show finger marks more readily than it will do when it has achieved this 'patina'. Regular cleaning with warm soapy water is the usual first step to remove surface marks.

If grease marks remain, the gentle abrasive of Cif cream cleaner will remove most marks without harming the surface at all. This sort of cleaner has a positive effect on the acrylic surface. For very stubborn grease marks or burnt on areas of fat splashes for instance, Fairy Power Spray will cut through this very easily.

### Solid Surface Clean & Care

Solid Surface Clean & Care is designed with easy clean technology, creating an invisible shield that helps prevent everyday dirt adhering to the worktops. The powerful quick cleaning formula easily tackles grease & grime ensuring a streak and spot free finish to your worktop. Apply a generous amount to the surface to be cleaned, and wipe off with a clean cloth. For any stubborn dirt, repeat the application and leave for 1 minute before wiping.

1. Everyday marks - Using a mild abrasive cleaner such as Cif cream, work in a circular motion; wipe away all residue and buff dry.
2. Fine scuffs and scratches - Cover the affected area with a liberal amount of soapy water. Place the grey abrasive pad\* onto the wet surface and, using a sanding block\* or firm sponge to ensure even spread of pressure, rub over the affected area in a circular motion. A slight paste will be generated that aids the finishing process and helps to maintain the original level of surface finish. Repeat step 1 if marks are still evident, repeat the grey abrasive pad process.

Avoid contact with aggressive chemical substances such as nail polish remover, chlorine, acetone, drain cleaner etc.

Do not use very abrasive cleaners and solvents as cleaning agents.

crosswater<sup>®</sup>

For any further information please contact  
Crosswater on: **0345 873 8840**

Or visit our web-site at: [www.crosswater.co.uk](http://www.crosswater.co.uk)

The manufacturer reserves the right to make  
technical modifications without prior notice.